



三合微科股份有限公司  
SAMHOP Microelectronics Corp.

**SM7513**

---

**3W STEREO AUDIO POWER AMPLIFIER WITH UP / DOWN GAIN CONTROL**

---

**SM7513**

**3W STEREO AUDIO POWER AMPLIFIER  
WITH UP / DOWN GAIN CONTROL**

**REV. 1.0**

**APRIL 30, 2007**

**The information in this document is subject to change without notice.  
© SAMHOP Microelectronics Corp. All Rights Reserved.**

---

台北縣新店市民權路100號7樓  
7F, No. 100, Min-Chyuan Road, Hsintien, Taipei Hsien, Taiwan, R.O.C.  
TEL: 886-2-2218-3978/2820 FAX: 886-2-2218-3320  
Email : [info@samhop.com.tw](mailto:info@samhop.com.tw)

**3W STEREO AUDIO POWER AMPLIFIER WITH UP / DOWN GAIN CONTROL****GENERAL DESCRIPTION**

The SM7513 is a stereo audio power amplifier that drives 3 W/channel of continuous RMS power into a 3- $\Omega$  load. Advanced up/down volume control minimizes external components and allows BTL (speaker) volume control and SE (earphone) volume control. Wireless headphone benefit from the integrated feature set that minimizes external components without sacrificing functionality.

To simplify design, the speaker volume level is adjusted by applying a up/down gain control to the up/down terminals.

**FEATURES**

- \* Advanced DC Volume Control With 2-dB Steps  
From -40 dB to 20 dB
- \* Depop circuitry
- \* Low quiescent current
- \* 1 $\mu$ A shutdown current
- \* 3W into 3 $\Omega$  from 5.5V supply
- \* Thermal protection
- \* Compact configuration and minimum external components

**APPLICATIONS**

- \* Mini Speaker
- \* Wireless headphone
- \* Car multimedia system

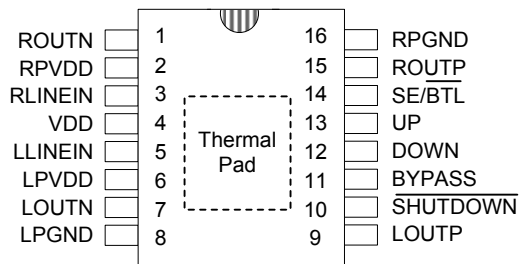
**PIN ASSIGNMENTS (TOP VIEW)****SM7513 16PIN**



**3W STEREO AUDIO POWER AMPLIFIER WITH UP / DOWN GAIN CONTROL**

**PIN ASSIGNMENTS**

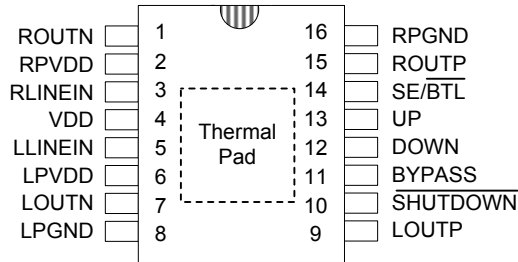

**SM7513 16PIN**

**PIN DESCRIPTIONS**

No.	Pin Name	I / O	Function
1	ROUTN	O	Right channel negative audio output
2	RPVDD	-	Supply voltage terminal for power stage
3	RLINEIN	I	Right channel line input
4	VDD	-	Supply voltage terminal
5	LLINEIN	I	Left channel line input
6	LPVDD	-	Supply voltage terminal for power stage
7	LOUTN	O	Left channel negative audio output
8	LPGND	-	Power ground
9	LOUTP	O	Left channel positive audio output
10	$\overline{\text{SHUTDOWN}}$	I	Places the amplifier in shutdown mode if a TTL logic low is placed on this terminal
11	BYPASS	I	Tap to voltage divider for internal midsupply bias generator used for analog reference
12	DOWN	I	Terminal for volume down control, high active
13	UP	I	Terminal for volume up control, high active
14	$\overline{\text{SE/BTL}}$	I	Output MUX control. When this terminal is high, SE outputs are selected. When this terminal is low, BTL outputs are selected
15	ROUTP	O	Right channel positive audio output
16	RPGND	-	Power ground

**3W STEREO AUDIO POWER AMPLIFIER WITH UP / DOWN GAIN CONTROL****MAXIMUM RATINGS (Ta = 40~85°C)**

Characteristic	Symbol	Rating	Unit
Supply Voltage, V <sub>DD</sub> , PV <sub>DD</sub>	V <sub>SS</sub>	-0.3 ~ 6	V
Input Voltage	V <sub>I</sub>	- 0.3 ~ V <sub>DD</sub> +0.3	V
Continuous total power dissipation	-	See Dissipation Rating Table	-
Operating junction temperature range	T <sub>J</sub>	- 40 ~ 150	°C
Storage temperature range	T <sub>stg</sub>	- 65 ~ 150	°C
Lead temperature 1,6 mm (1/16 inch) from case for 10 seconds	-	260	°C

**DISSIPATION RATING TABLE**

PACKAGE	T <sub>A</sub> ≤25°C Power Rating	Derating Factor Above T <sub>A</sub> =25°C	T <sub>A</sub> =70°C Power Rating	T <sub>A</sub> =85°C Power Rating
SOP /SSOP	2.7mW	21.8 mW/°C	1.7W	1.4W

**RECOMMENDED OPERATING CONDITION**

Characteristic	Symbol	Condition	Min.	Typ.	Max.	Unit
Supply Voltage, V <sub>DD</sub> , PV <sub>DD</sub>	V <sub>SS</sub>	--	4.0		5.5	V
High-level input voltage	V <sub>IH</sub>	SE/BTL, UP, DOWN	0.8 V <sub>DD</sub>			V
	V <sub>IH</sub>	SHUTDOWN	2.0			
Low-level input voltage	V <sub>IL</sub>	SE/BTL, UP, DOWN			0.4 V <sub>DD</sub>	V
	V <sub>IL</sub>	SHUTDOWN			0.6	
Operating free-air temperature	T <sub>A</sub>	--	-40		85	°C



**3W STEREO AUDIO POWER AMPLIFIER WITH UP / DOWN GAIN CONTROL**

**ELECTRICAL CHARACTERISTICS (V<sub>DD</sub> =PV<sub>DD</sub> = 5.5V, Ta = 25°C unless otherwise noted)**

Characteristic	Symbol	Condition	Min.	Typ.	Max.	Unit
Output offset voltage (measured differentially)	V <sub>OO</sub>	V <sub>DD</sub> =5.5V, Gain=20dB, SE/ $\overline{\text{BTL}}$ =0V			60	mV
Power supply rejection ratio	PSRR	V <sub>DD</sub> =PV <sub>DD</sub> =4.0V to 5.5V	-42	-70		dB
High-level input current (SE/BTL, SHUTDOWN)	I <sub>IH</sub>	V <sub>DD</sub> =PV <sub>DD</sub> =5.5V, V <sub>I</sub> =V <sub>DD</sub> =PV <sub>DD</sub>			1	uA
Low-level input current(SE/BTL, SHUTDOWN, VOLUME)	I <sub>IL</sub>	V <sub>DD</sub> =PV <sub>DD</sub> =5.5V, V <sub>I</sub> =0V			1	uA
Supply current, no load	I <sub>DD</sub>	V <sub>DD</sub> =PV <sub>DD</sub> =5.5V, SE/ $\overline{\text{BTL}}$ =0V, SHUTDOWN=2V	5.5	8.0	10	mA
		V <sub>DD</sub> =PV <sub>DD</sub> =5.5V, SE/ $\overline{\text{BTL}}$ =5.5V, SHUTDOWN=2V	3.0	5.0	6.0	
Supply current,max power into a 3Ω load	I <sub>DD</sub>	V <sub>DD</sub> =5V=PV <sub>DD</sub> , SE/ $\overline{\text{BTL}}$ =0V, SHUTDOWN=2V, R <sub>L</sub> =3Ω, P <sub>O</sub> =2W, Stereo		1.5		ARMS
Supply current,shutdown mode	I <sub>DD(SD)</sub>	$\overline{\text{SHUTDOWN}}$ =0.0V		1	20	uA

**OPERATING CHARACTERISTICS**

(V<sub>DD</sub> =PV<sub>DD</sub> = 5V, R<sub>L</sub> = 3Ω, Gain = 6dB, Ta = 25°C unless otherwise noted)

Characteristic	Symbol	Condition	Min.	Typ.	Max.	Unit
Output Power <sup>(1)</sup>	P <sub>O</sub>	THD=1%, f=1 kHz, R <sub>L</sub> =4Ω		1.9		W
		THD=10%, f=1 kHz, R <sub>L</sub> =4Ω		2.4		
		THD=1%, f=1 kHz, R <sub>L</sub> =8Ω		1.3		
		THD=10%, f=1 kHz, R <sub>L</sub> =8Ω		1.6		
		THD=10%, f=1 kHz, R <sub>L</sub> =3Ω, V <sub>DD</sub> =5.5V		3		
Total harmonic distortion+noise	THD+N	P <sub>O</sub> =1W, R <sub>L</sub> =8Ω, f=20Hz to 20kHz		< 0.6		%
High-level output voltage	V <sub>OH</sub>	R <sub>L</sub> =8Ω, Measured between output and V <sub>DD</sub>			600	mV
Low-level output voltage	V <sub>OL</sub>	R <sub>L</sub> =8Ω, Measured between output and GND			400	mV
Bypass voltage(Nominally V <sub>DD</sub> /2) <sup>(2)</sup>	V <sub>(BYPASS)</sub>	Measured at pin 11, No load, V <sub>DD</sub> =5.5V	2.65	2.75	2.85	V
Maximum output power bandwidth	BOM	THD = 5%		> 20		kHz
Supply ripple rejection ratio		f=1 kHz, Gain = 0 dB, C <sub>(BYP)</sub> = 0.47uF	$\overline{\text{BTL}}$	-63		dB
			SE	-57		
Initial gain		f= 1kHz, R <sub>L</sub> = 8Ω	-2	-4	-6	dB

(1) Output power is measured at the output terminals of the IC.

(2) At 4V < V<sub>DD</sub> < 5.5V the DC bypass voltage is approximately V<sub>DD</sub>/2



3W STEREO AUDIO POWER AMPLIFIER WITH UP / DOWN GAIN CONTROL

FUNCTIONAL BLOCK DIAGRAM

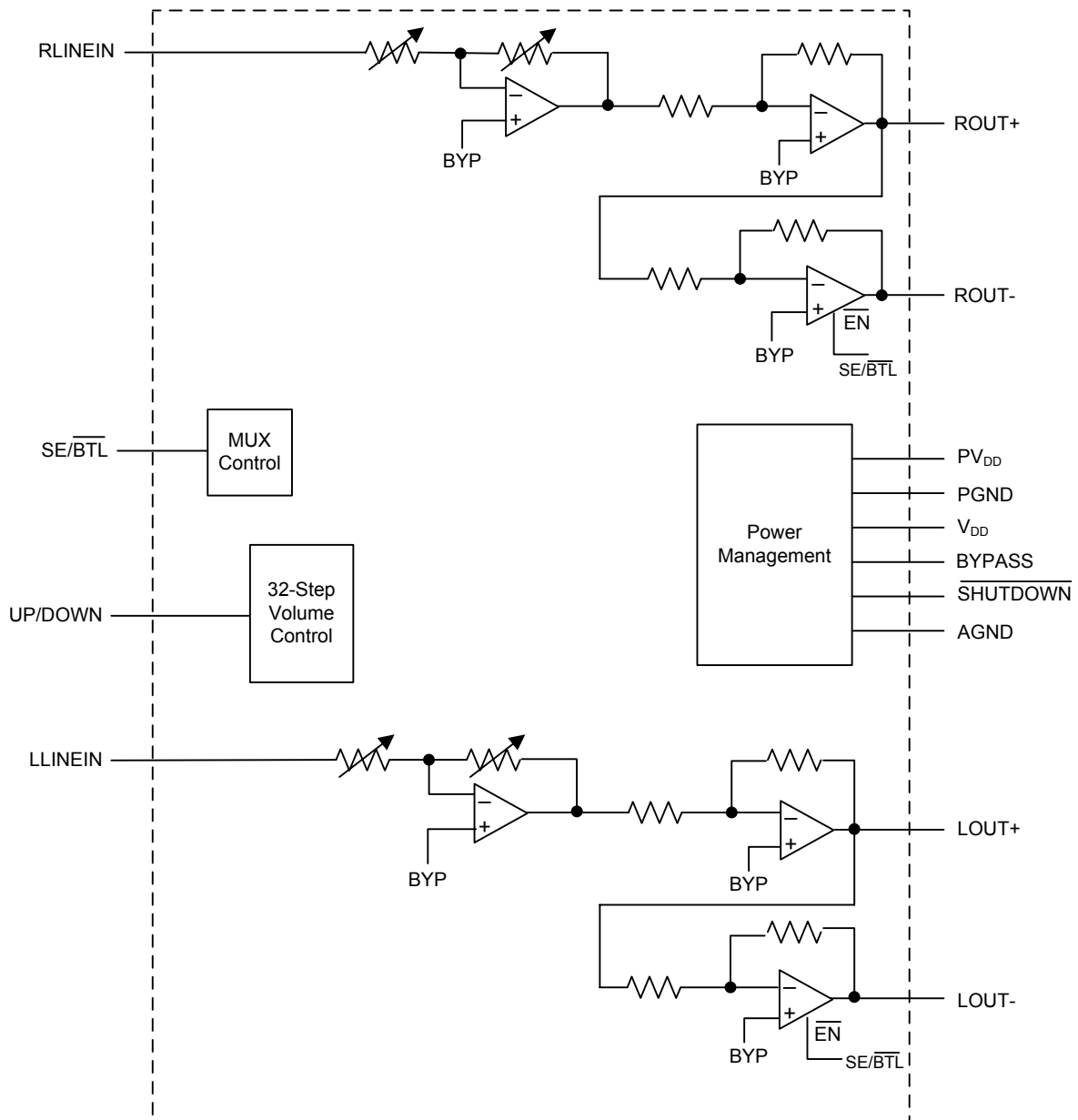



3W STEREO AUDIO POWER AMPLIFIER WITH UP / DOWN GAIN CONTROL

APPLICATION INFORMATION

The figure is schematic diagram of typical for car multimedia system application circuit.

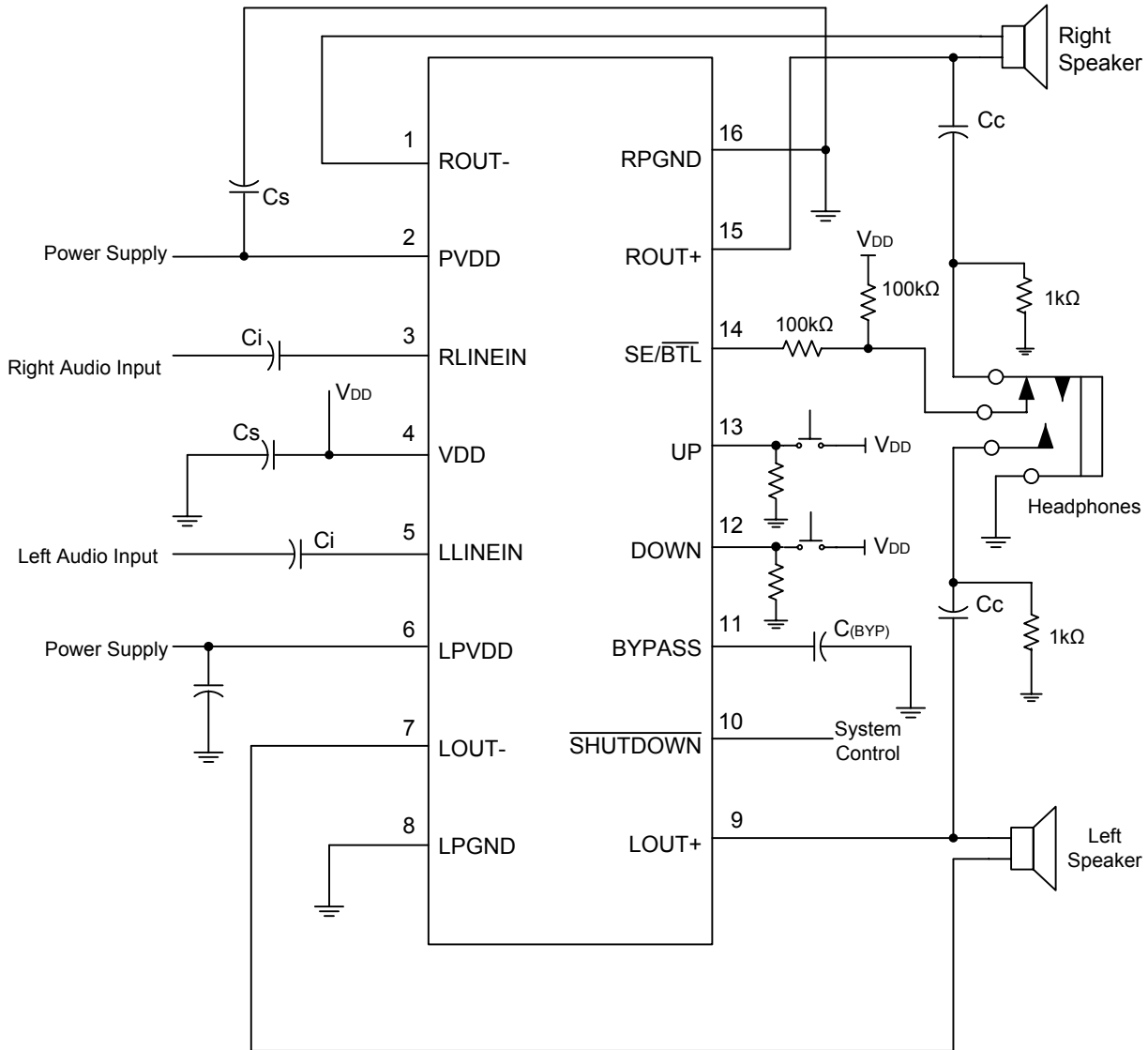

Figure 1. SM7513 Using stereo line inputs application circuit



**3W STEREO AUDIO POWER AMPLIFIER WITH UP / DOWN GAIN CONTROL**

**VOLUME CONTROL**

The output volume of SM7513 is respectively controlled by two input pins, UP and Down pin. The UP pin controls the volume increment, and the DOWN pin controls the volume decrement. It increases/decreases  $\pm 2\text{dB}$  each step. Both are all active high. The SM7513 built-in a RC oscillator and generates a based frequency for volume output register to count increasingly or decreasingly. It starts to count when the UP/DOWN pin is pressed. If the voltage on UP/DOWN pin is disappeared in specific unit period, the volume increment or decrement is not accepted, which means no action, keeps the original voltage and clears the value in count register. Therefore, there is no increment or decrement to make the volume uncertainly. After power on or shutdown, SM7513 will has  $-4\text{dB} \pm 2\text{dB}$  initial gain.

The mapping between output volume increment / decrement and active unit period is shown in Figure 2. When the UP Key keeps high for one active unit period, the output gain increases 2db after the Key is released. When the UP Key keeps low and the DOWN Key become high level for one active unit period, the output gain decreases 2db.

The action of pressed the UP/DOWN Key continually is shown in Figure 3. The gain is increased/ decreased after one unit periods. If the Key is continually be pressed more than two unit periods, the gain is increased/ decreased until to maximum 20dB or -65dB.

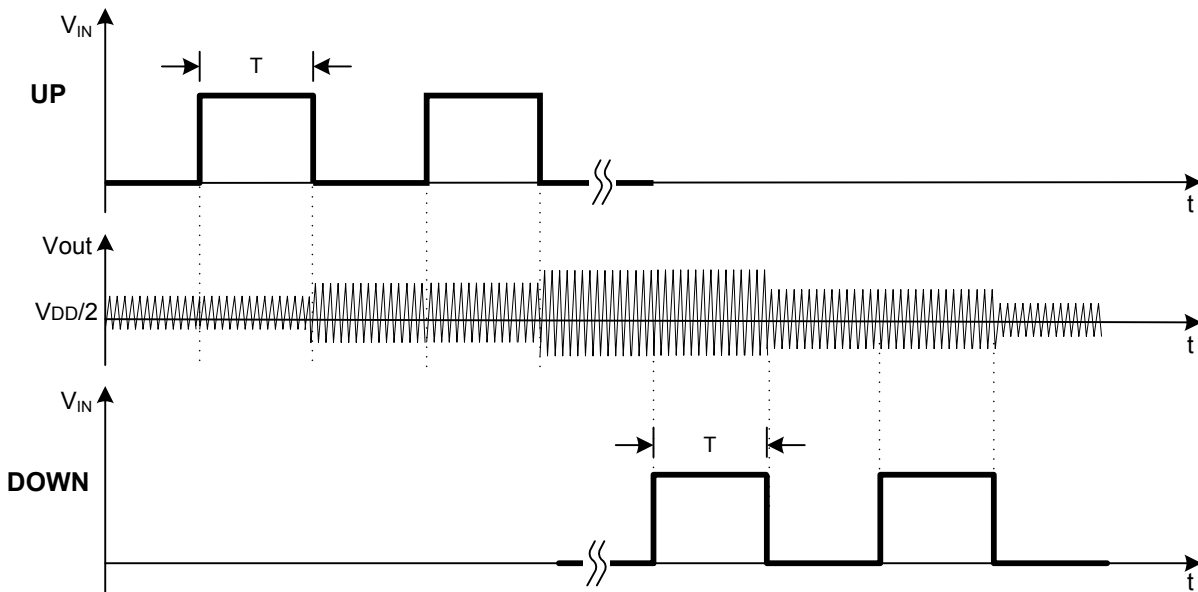

Figure 2 . How the volume change with respect to Up/Down timing cotrol

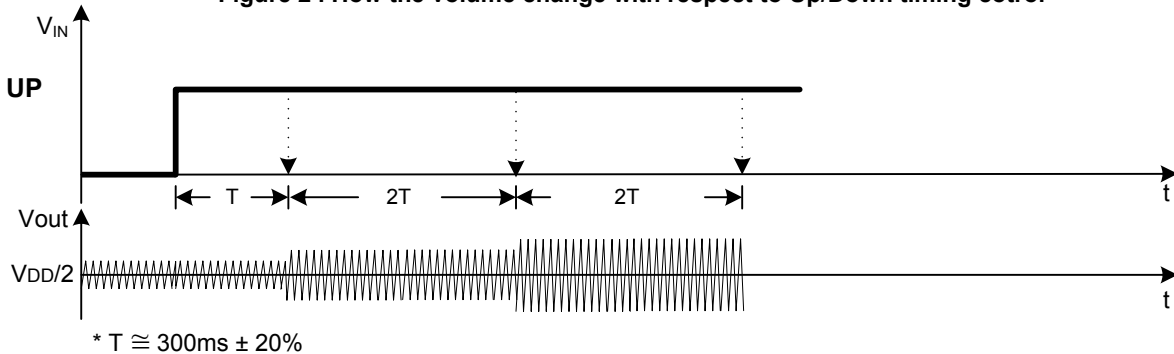

Figure 3. Up key be pressed continually





3W STEREO AUDIO POWER AMPLIFIER WITH UP / DOWN GAIN CONTROL

THD+N vs. FREQUENCY

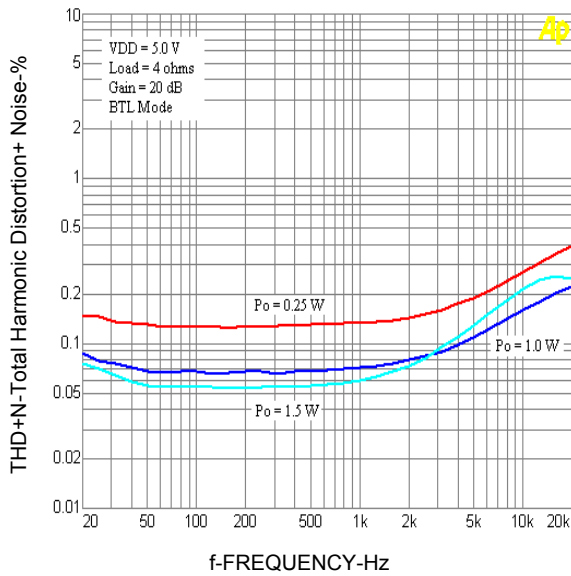

THD+N vs. FREQUENCY

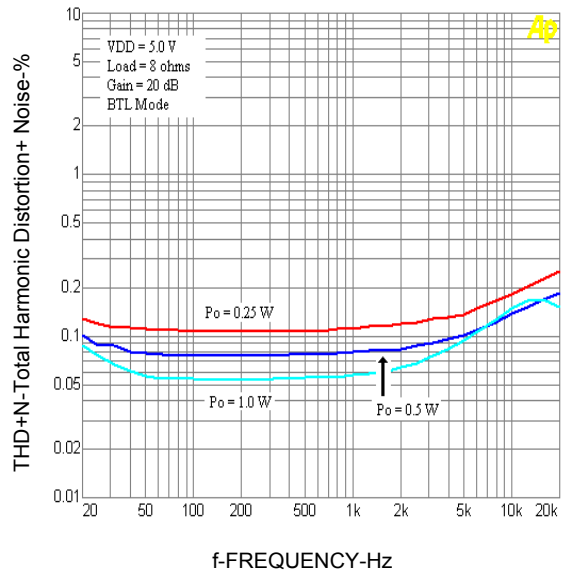

THD+N vs. FREQUENCY

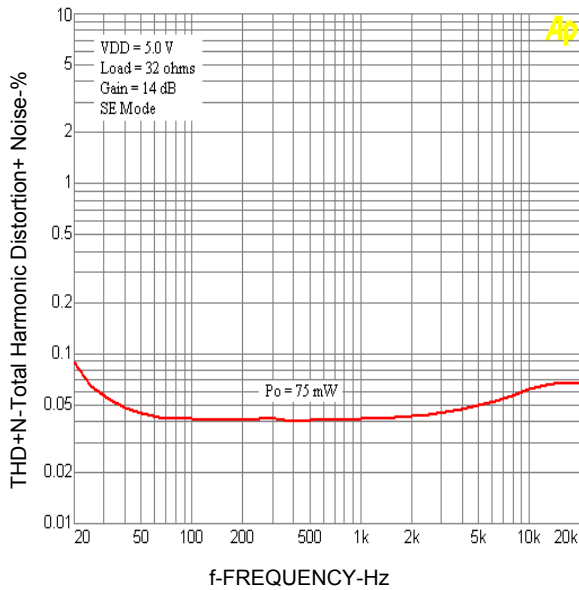

THD+N vs. Pout

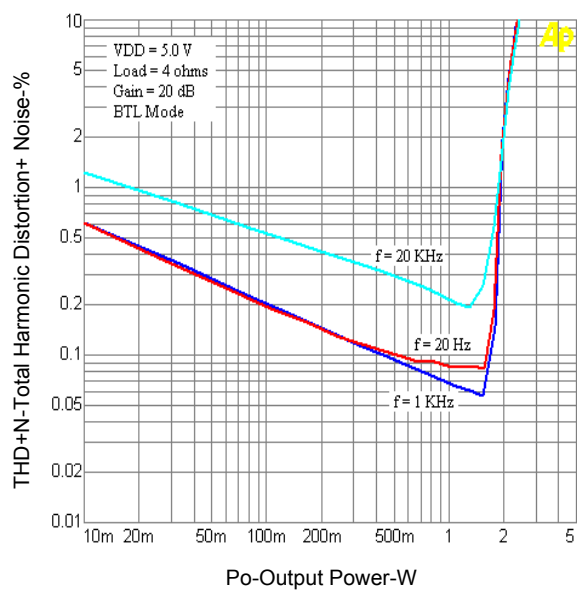



3W STEREO AUDIO POWER AMPLIFIER WITH UP / DOWN GAIN CONTROL

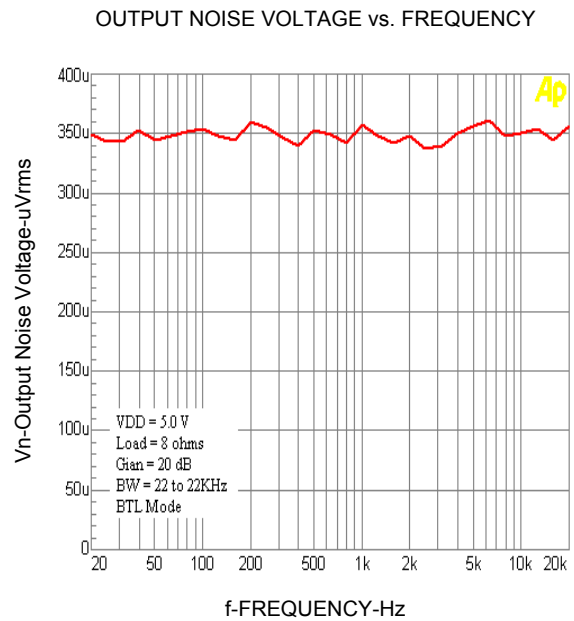
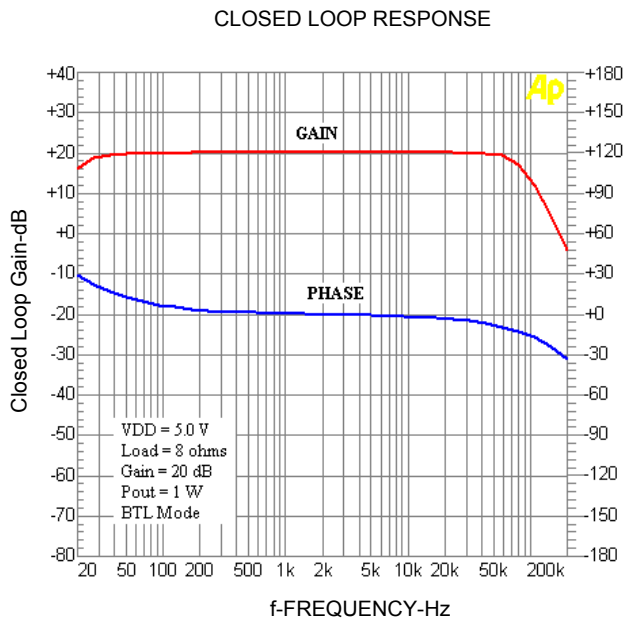
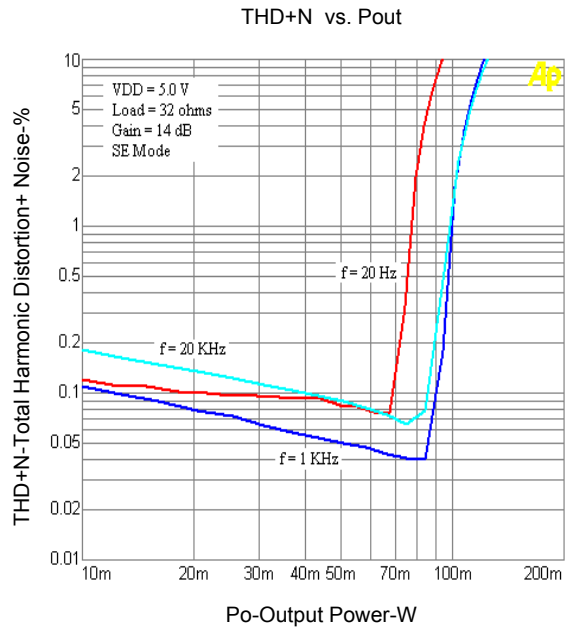
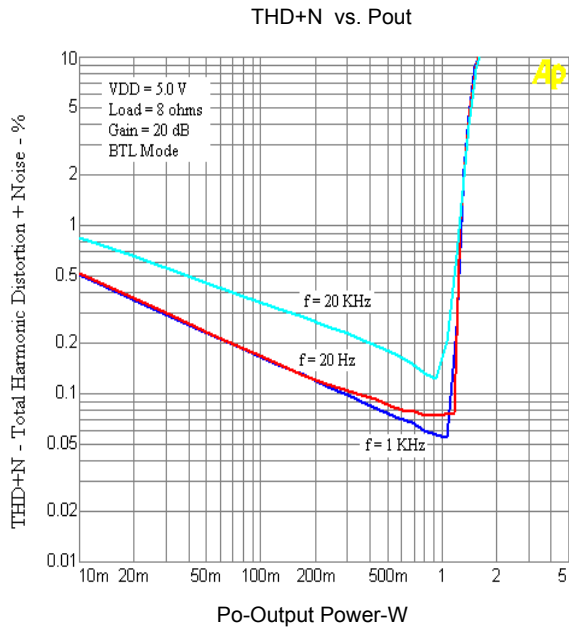



**3W STEREO AUDIO POWER AMPLIFIER WITH UP / DOWN GAIN CONTROL**

**PACKAGE OUTLINE**

SM7513S 16PIN SOP

Unit : mm

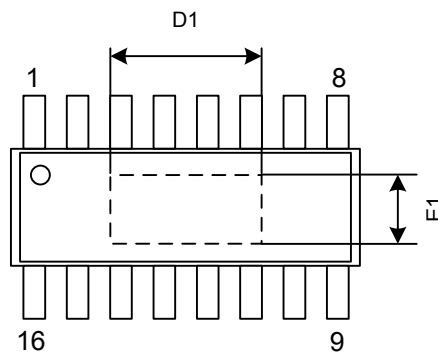
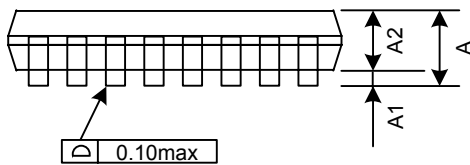
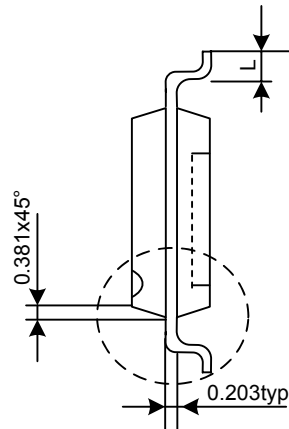
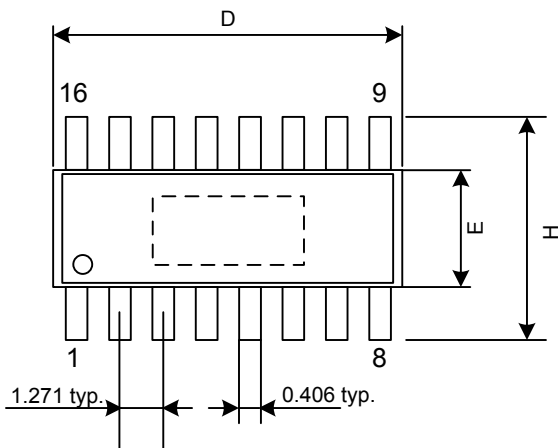

SYMBOLS	MIN.	NOM.
A	1.35	1.75
A1	0.05	0.15
D	9.81	10.02
E	3.81	4.0
H	5.80	6.20
L	0.41	1.27
$\theta^\circ$	0°	8°

**THERMALLY ENHANCED DIMENSIONS**

PAD DICE	E1	D1
95 x 18E	2.19 REF	4.12 REF

**NOTES:**

1. JEDEC OUTLINE : N/A
2. DIMENSIONS "D" DOES NOT INCLUDE MOLD FLASH, PROTRUSIONS OR GATE BURRS. MOLD FLASH PROTRUSIONS AND GATE BURRS SHALL NOT EXCEED 0.15mm PER SIDE.
3. DIMENSION "E" DOES NOT INCLUDE INTER-LEAD FLASH, OR PROTRUSIONS. INTER-LEAD FLASH AND PROTRUSIONS SHALL NOT EXCEED 0.25mm PER SIDE.



3W STEREO AUDIO POWER AMPLIFIER WITH UP / DOWN GAIN CONTROL

PACKAGE OUTLINE

SM7513F 16PIN SSOP

Thermal Pad

Unit : mm

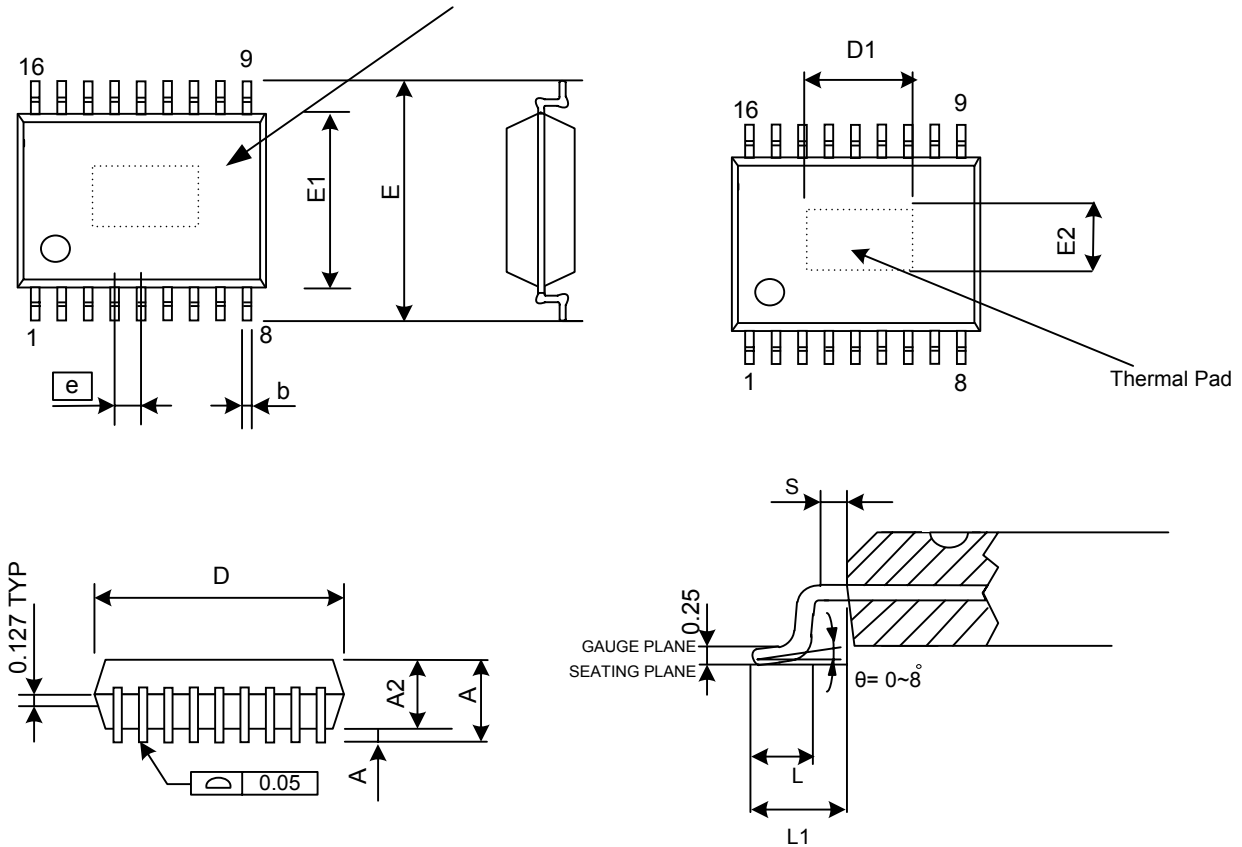

SYMBOLS	MIN.	NOM.	MAX.
A	—	—	1.20
A1	0.00	—	0.15
A2	0.80	1.00	1.05
b	0.19	—	0.30
D	4.90	5.00	5.10
E1	4.30	4.40	4.50
E	6.40 BSC		
e	0.65 BSC		
L1	1.00 REF		
L	0.45	0.60	0.75
s	0.20	—	—
θ	0°	—	8°

NOTES:

- JEDEC OUTLINE:  
MO-153 AB/MO-153 ABT(THERMALLY VARIATIONS ONLY)
- DIMENSIONS " D " DOES NOT INCLUDE MOLD FLASH, PROTRUSIONS OR GATE BURRS.MOLD FLASH PROTRUSIONS AND GATE BURRS SHALL NOT EXCEED 0.15mm PER SIDE.
- DIMENSION " E " DOES NOT INCLUDE INTER-LEAD FLASH, OR PROTRUSIONS. INTER-LEAD FLASH AND PROTRUSIONS SHALL NOT EXCEED 0.25mm PER SIDE.

THERMALLY ENHANCED DIMENSIONS

PAD DICE	E1		D1	
	MIN.	MAX.	MIN.	MAX.
118 x 11E	1.98	3.00	1.98	3.00



---

**3W STEREO AUDIO POWER AMPLIFIER WITH UP / DOWN GAIN CONTROL**

---

**Ordering Information**

Package	Marking	Part Number ( Tape and Reel )
SOP-16	SM7513S	SM7513S
SSOP-16	SM7513F	SM7513F

**Lead Free Information**

Package	Marking	Lead Free Part Number
SOP-16	SM7513SL	SM7513SL
SSOP-16	SM7513FL	SM7513FL

**Green Information**

Package	Marking	Green Part Number
SOP-16	SM7513SG	SM7513SG
SSOP-16	SM7513FG	SM7513FG